

ABUTMENTS' MACRO-DESIGN CHARACTERISTICS

1. Many abutments, which differ in diameter, height, abutment inclination, and size of gingival part, are compatible with the inner hexagon platform of all implants in the aforementioned system.
2. To facilitate certain positioning toward the implant, there are two options of the abutment body rotation to its hexagon: either to the hexagon angle or to the hexagon facet in the horizontal plane. Due to this, the maximum value of rotation angle makes 30 degrees.
3. For the better aesthetics, there is a possibility of integrating zirconium abutments. In the framework of temporary prosthetics, plastic abutments can be used.

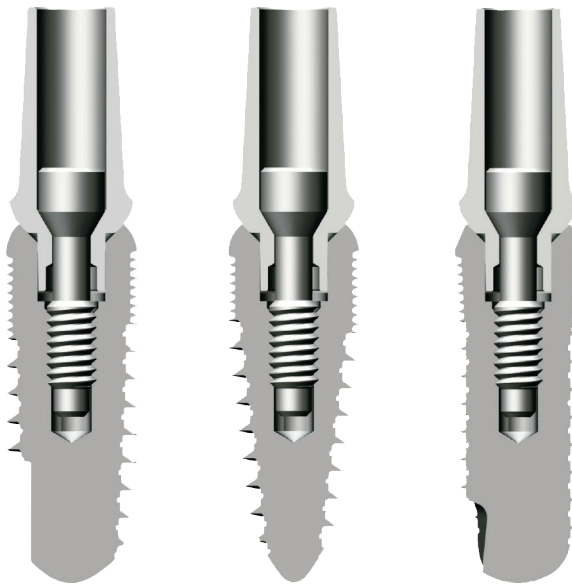

UNIVERSAL IMPLANTS, NHI-1

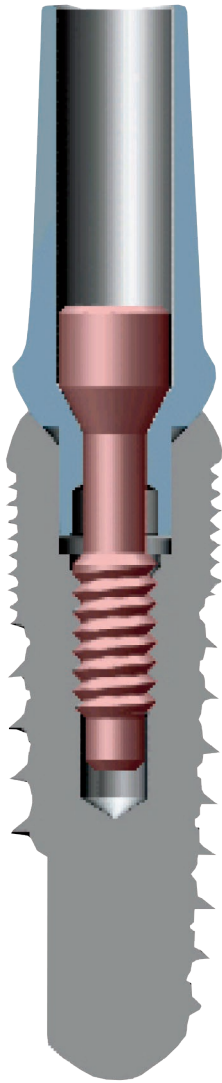

3.75

NHI-1 3.75

Length mm	8	10	11.5	13	15
Ø 3.75 mm	NHI-1_375_080	NHI-1_375_100	NHI-1_375_115	NHI-1_375_130	NHI-1_375_150



4.20

NHI-1 4.20

Length mm	8	10	11.5	13	15
Ø 4.20 mm	NHI-1_420_080	NHI-1_420_100	NHI-1_420_115	NHI-1_420_130	NHI-1_420_150

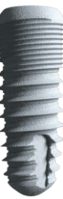

4.75

NHI-1 4.75

Length mm	8	10	11.5	13	15
Ø 4.75 mm	NHI-1_475_080	NHI-1_475_100	NHI-1_475_115	NHI-1_475_130	NHI-1_475_150

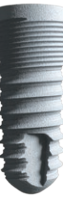

5.20

NHI-1 5.20

Length mm	8	10	11.5	13	15
Ø 5.20 mm	NHI-1_520_080	NHI-1_520_100	NHI-1_520_115	NHI-1_520_130	NHI-1_520_150

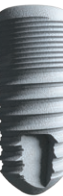

5.75

NHI-1 5.75

Length mm	8	10	11.5	13	15
Ø 5.75 mm	NHI-1_575_080	NHI-1_575_100	NHI-1_575_115	NHI-1_575_130	NHI-1_575_150

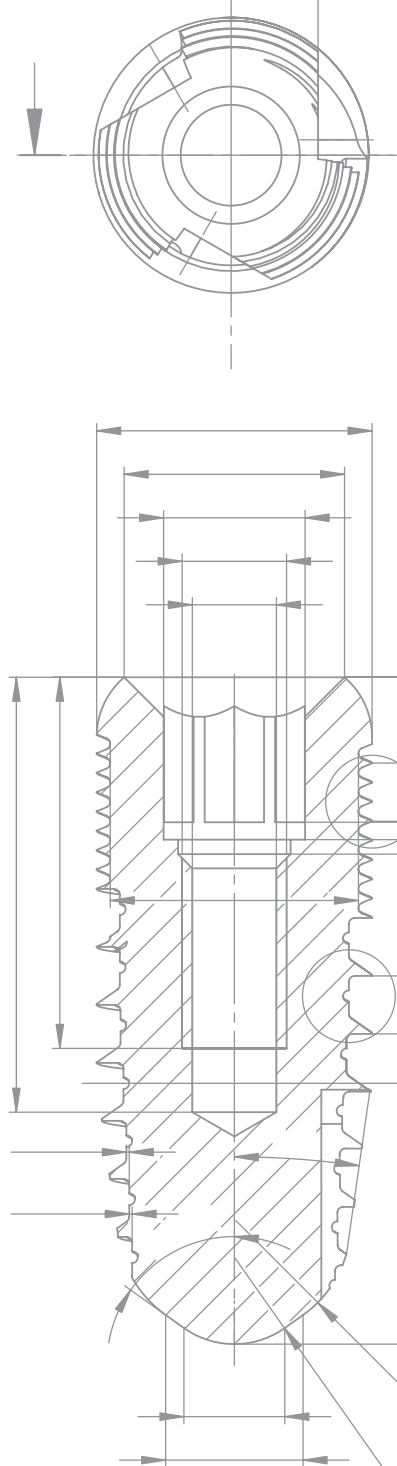

The set of universal implants NHI-1 is designed, manufactured and assembled to ensure a successful implantation and, based on the integrated implants, to form safe dental-orthopedic structures, taking into account a wide variety of f bone, including anatomic and topographic features of the patients' upper and lower jaws.

The implants NHI-1 are characterized by their low-grade conical design and self-cutting thread with groove.

The implants NHI-1 are also distinguished through three types of thread and knife-edges distributed along the implant length. Due to the elaboration and implementation of such structure, the following issues were handled:

- less traumatic penetration and smooth osseointegration of the implant;
- expansion of the implant's direct contact area with the bone;
- increased density and stability of the connection between bone and implant;

- dispersal and more uniform distribution of occlusal pressure on the bone.

Undoubtedly, all these factors contribute to successful osseointegration and safe functioning of the dental and orthopedic structures based on the integrated implants.

The technique of implant insertion shall comprise a sequence of the following operations:

- preliminary drilling of the bone with a thin pilot-drill. This process operation shall be performed either by using special conical drills or a set of cylindrical drills with expanding diameter and decreasing canal size, subject to the immersion of drill;
- insertion of implant into the prepared bone bed. This process operation shall be performed by means of applying a reusable detachable implant-driver.

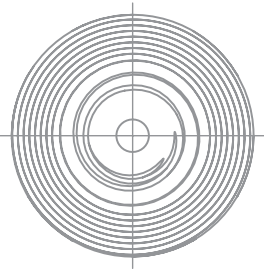

CONICAL IMPLANTS, TYPE NHI-2



3.75

NHI-2 3.75

Length mm	8	10	11.5	13	15
∅ 3.75 mm	NHI-2_375_080	NHI-2_375_100	NHI-2_375_115	NHI-2_375_130	NHI-2_375_150



4.20

NHI-2 4.20

Length mm	8	10	11.5	13	15
∅ 4.20 mm	NHI-2_420_080	NHI-2_420_100	NHI-2_420_115	NHI-2_420_130	NHI-2_420_150



4.75

NHI-2 4.75

Length mm	8	10	11.5	13	15
∅ 4.75 mm	NHI-2_475_080	NHI-2_475_100	NHI-2_475_115	NHI-2_475_130	NHI-2_475_150

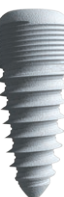

5.20

NHI-2 5.20

Length mm	8	10	11.5	13	15
∅ 5.20 mm	NHI-2_520_080	NHI-2_520_100	NHI-2_520_115	NHI-2_520_130	NHI-2_520_150



5.75

NHI-2 5.75

Length mm	8	10	11.5	13	15
∅ 5.75 mm	NHI-2_575_080	NHI-2_575_100	NHI-2_575_115	NHI-2_575_130	NHI-2_575_150

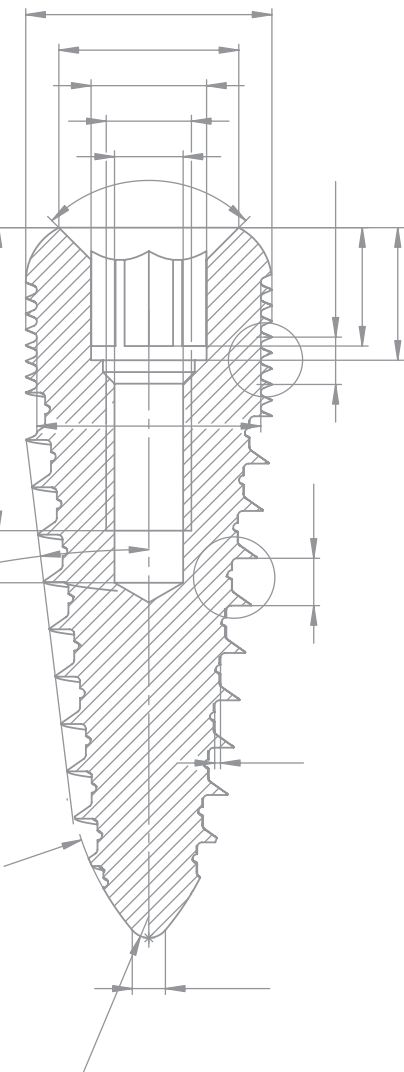

The set of conical implants NHI-2 is designed, manufactured and assembled for implantation into the soft, spongy bone of the upper jaw, refined parts of the lower jaw and narrow places between the roots of contiguous teeth.

The implants NHI-2 are designed to provide a better coherence with commonly spread anatomical features and topographic characteristics of the upper jaw.

The implants NHI-2 are distinguished through their pronounced conicity, self-cutting aggressive thread and sharp bayonet apex. Such structure contributes to lateral condensation of the bone and uniform load

distribution in the densification of bone trabeculae. Thus successful osseointegration is provided and favorable conditions are created for the formation of reliable orthopedic structures on the spongy bone.

The inserting technique of NHI-2 implants shall comprise a preliminary preparation of the bone bed, followed by the process of implants screwing through the usage of proper thread and bayonet apex thereof.

The bone bed shall be formed with drills of minor diameters. Drill diameters shall be selected, taking into account the bone density and the possibility of providing a reliable lateral bone condensation.

CYLINDRICAL IMPLANTS, TYPE NHI-3



3.75

NHI-3 3.75

Length mm	8	10	11.5	13	15
∅ 3.75 mm	NHI-3_375_080	NHI-3_375_100	NHI-3_375_115	NHI-3_375_130	NHI-3_375_150



4.20

NHI-3 4.20

Length mm	8	10	11.5	13	15
∅ 4.20 mm	NHI-3_420_080	NHI-3_420_100	NHI-3_420_115	NHI-3_420_130	NHI-3_420_150



4.75

NHI-3 4.75

Length mm	8	10	11.5	13	15
∅ 4.75 mm	NHI-3_475_080	NHI-3_475_100	NHI-3_475_115	NHI-3_475_130	NHI-3_475_150



5.20

NHI-3 5.20

Length mm	8	10	11.5	13	15
∅ 5.20 mm	NHI-3_520_080	NHI-3_520_100	NHI-3_520_115	NHI-3_520_130	NHI-3_520_150

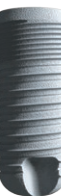

5.75

NHI-3 5.75

Length mm	8	10	11.5	13	15
∅ 5.75 mm	NHI-3_575_080	NHI-3_575_100	NHI-3_575_115	NHI-3_575_130	NHI-3_575_150

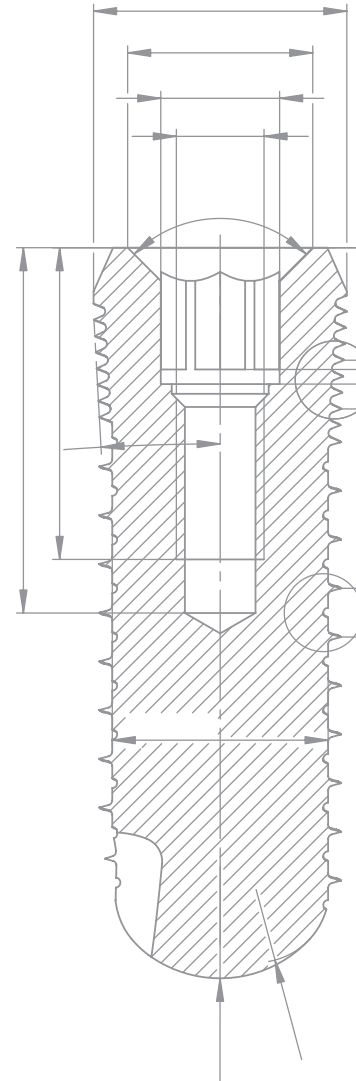
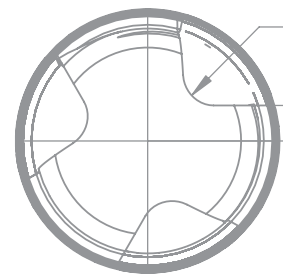

The set of self-cutting cylindrical implants NHI-3 are designed to form reliable implant-orthopedic structures on solid and hollow bones of the lower jaw and under sinus-lift conditions of the upper jaw.

The set of implants NHI-3 has the following features:

- medium-sized, low-grade atraumatic thread in lower 2/3 parts of the implant's body for smooth penetration and good connection between the implant and the bone;
- spherical form of apical part, which contributes to uniform distribution of load on the bone's bed bottom and on the osseous chips, as well as creates favorable conditions for implants' ossification;
- three special sockets distributed along the apical part with sharp knife-edges assigned to collect bone chips;
- cervical part executed as micro-thread with low-grade conicity.

Such structure prevents the resorption of the bone's marginal part and provides a better bilateral biomechanical connection in the implant's upper part.

Thus, the totality of structural features intrinsic to the set of implants NHI-3 creates favorable conditions for successful osseointegration, as well as for the formation of safe orthopedic structures on solid and hollow bones of the lower jaw and sinus-lifts on the upper jaw.

The technique of inserting implants NHI-3 shall comprise a preliminary creation of the bone bed by using cylindrical drills with a diameter close to the implant diameter.

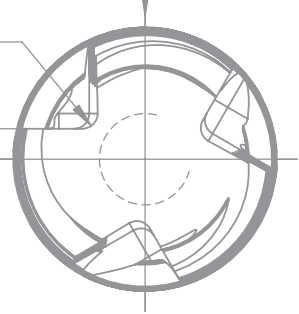

IMPLANTS SET, TYPE NHI-4

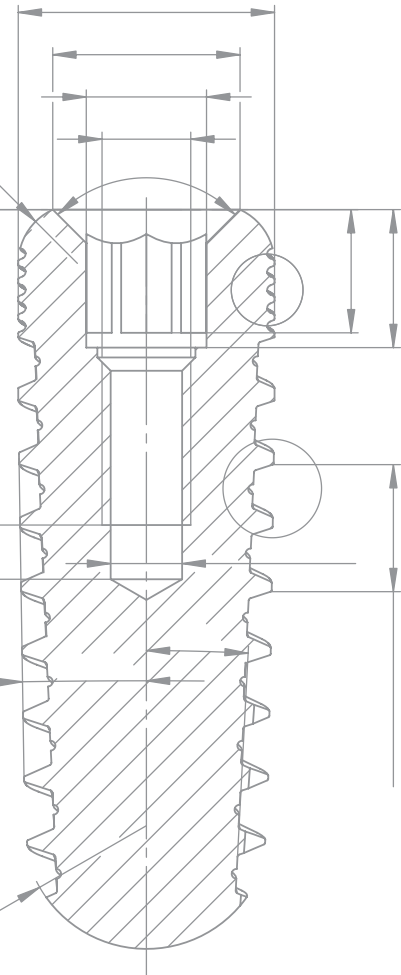

3.75

NHI-4 3.75

Length mm	8	10	11.5	13	15
∅ 3.75 mm	NHI-5_375_080	NHI-5_375_100	NHI-5_375_115	NHI-5_375_130	NHI-5_375_150



4.20

NHI-4 4.20

Length mm	8	10	11.5	13	15
∅ 4.20 mm	NHI-5_420_080	NHI-5_420_100	NHI-5_420_115	NHI-5_420_130	NHI-5_420_150



4.75

NHI-4 4.75

Length mm	8	10	11.5	13	15
∅ 4.75 mm	NHI-5_475_080	NHI-5_475_100	NHI-5_475_115	NHI-5_475_130	NHI-5_475_150



5.20

NHI-4 5.20

Length mm	8	10	11.5	13	15
∅ 5.20 mm	NHI-5_520_080	NHI-5_520_100	NHI-5_520_115	NHI-5_520_130	NHI-5_520_150



5.75

NHI-4 5.75

Length mm	8	10	11.5	13	15
∅ 5.75 mm	NHI-5_575_080	NHI-5_575_100	NHI-5_575_115	NHI-5_575_130	NHI-5_575_150

The set of implants NHI-4 is designed for upper and lower jaws of patients in soft bone conditions. Therefore, the main technical requirement to the development of corresponding constructive forms was attaining the necessary level of the soft bone lateral condensation while inserting the implants and their subsequent osseointegration.

The set of implants NHI-4 is specifically distinguished through its three types of thread and knife-edges distributed along the implant length, as well as through its smooth cutting depression and concomitant increase in the width of cogs' cut in the direction of the implants' cervical part.

Due to such structure, it is possible:

- to expand the implant's direct contact area with the soft bone;
- to ensure uniform lateral condensation of the soft bone, both in the implant's inter-thread and screw parts;
- to ensure dispersal and more uniform distribution of occlusal pressure on the bone, while inserting implants into the soft bone;
- to increase the density and solidity of biomechanical connection between the soft bone and the implant;

- to provide a less traumatic penetration and smooth osseointegration of the implant in the soft bone.

The totality of these factors intrinsic ensures a successful osseointegration and safe functioning of dental and orthopedic structures, based on the implants NHI-4 integrated into the soft bone.

The technique of the bone bed preparation and implant insertion shall comprise a sequence of the following operations:

- preliminary drilling of the bone with a thin cylindrical pilot-drill;
- consequent drilling by means of cylindrical drills with expanding diameter and gradual decreasing of the depth of drilling;
- flattening the hole surface with the finishing drill completes the formation of the bone bed for implant

Insertion of implant into the prepared bone bed shall be performed by means of a reusable detachable implant-driver.

IMPLANTS SET, TYPE NHI-5



NHI-5 3.75

Length mm	8	10	11.5	13	15
∅ 3.75 mm	NHI-5_375_080	NHI-5_375_100	NHI-5_375_115	NHI-5_375_130	NHI-5_375_150



NHI-5 4.20

Length mm	8	10	11.5	13	15
∅ 4.20 mm	NHI-5_420_080	NHI-5_420_100	NHI-5_420_115	NHI-5_420_130	NHI-5_420_150



NHI-5 4.75

Length mm	8	10	11.5	13	15
∅ 4.75 mm	NHI-5_475_080	NHI-5_475_100	NHI-5_475_115	NHI-5_475_130	NHI-5_475_150



NHI-5 5.20

Length mm	8	10	11.5	13	15
∅ 5.20 mm	NHI-5_520_080	NHI-5_520_100	NHI-5_520_115	NHI-5_520_130	NHI-5_520_150



NHI-5 5.75

Length mm	8	10	11.5	13	15
∅ 5.75 mm	NHI-5_575_080	NHI-5_575_100	NHI-5_575_115	NHI-5_575_130	NHI-5_575_150

The set of implants NHI-5 is designed for upper and lower jaws of patients in soft bone conditions. Therefore, the main technical requirement to the development of corresponding constructive forms was attaining the necessary level of the soft bone lateral condensation while inserting the implants and their subsequent osseointegration.

The set of implants NHI-5 is specifically distinguished through its three types of thread and knife-edges distributed along the implant length, as well as through its smooth cutting depression and concomitant increase in the width of cogs' cut in the direction of the implants' cervical part.

Due to such structure, it is possible:

- to expand the implant's direct contact area with the soft bone;
- to ensure uniform lateral condensation of the soft bone, both in the implant's inter-thread and screw parts;
- to ensure dispersal and more uniform distribution of occlusal pressure on the bone, while inserting implants into the soft bone;
- to increase the density and solidity of biomechanical connection between the soft bone and the implant;

- to provide a less traumatic penetration and smooth osseointegration of the implant in the soft bone.

The totality of these factors intrinsic ensures a successful osseointegration and safe functioning of dental and orthopedic structures, based on the implants NHI-5 integrated into the soft bone.

The technique of the bone bed preparation and implant insertion shall comprise a sequence of the following operations:

- preliminary drilling of the bone with a thin cylindrical pilot-drill;
- consequent drilling by means of cylindrical drills with expanding diameter and gradual decreasing of the depth of drilling;
- flattening the hole surface with the finishing drill completes the formation of the bone bed for implant

Insertion of implant into the prepared bone bed shall be performed by means of a reusable detachable implant-driver.

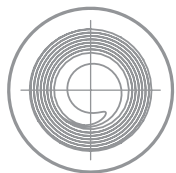

MINI-IMPLANTS, TYPE NHI-M

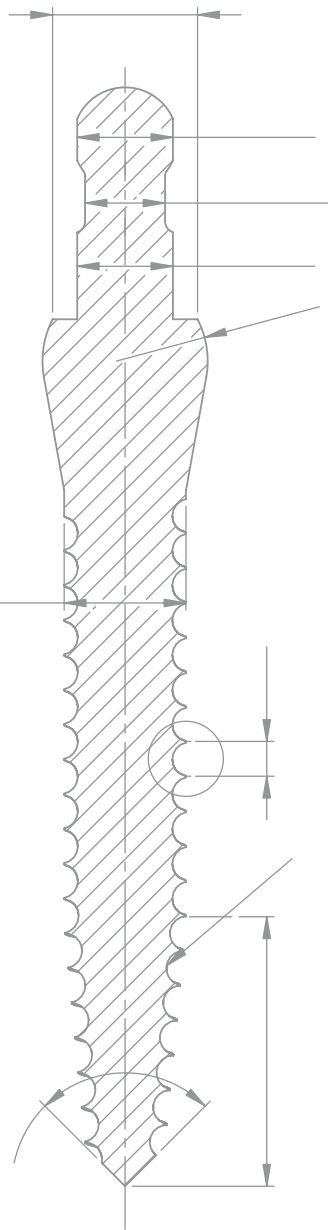

1.9

NHI-M 1.9

Length mm	8	10	12	14	16
Ø 1.9 mm	NHI-M_190_080	NHI-M_190_100	NHI-M_190_120	NHI-M_190_140	NHI-M_190_160



2.1

NHI-M 2.1

Length mm	8	10	12	14	16
Ø 2.1 mm	NHI-M_210_080	NHI-M_210_100	NHI-M_210_115	NHI-M_210_130	NHI-M_210_150

Characteristic features of the NHI-M implants and orthopedic structures on the basis of such implants:

- suitability for temporary and permanent removable dentures;
- possibility of performing implantation and prosthetics in one treatment session;
- denture is firmly fixed by a ball-head attachment and a special integrated therein case-matrix, equipped with a rubber ring retainer, tightly fitting the implant neck.

The set of mini-implants NHI-M is designed to be used as attachments in removable prosthetics in the upper and lower jaws in case of bone deficit.

The set of mini-implants NHI-M is attributed to the category of ultra-thin intra-jaw screw self-cutting implants.

SPECIAL IMPLANTS, TYPE NHI-S

5.50

NHI-S 5.50



Length mm	4.5	5	6	7
∅ 5.50 mm	NHI-S_550_045	NHI-S_550_050	NHI-S_550_060	NHI-S_550_070

6.0

NHI-S 6.0



Length mm	4.5	5	6	7
∅ 6.0 mm	NHI-S_600_045	NHI-S_600_050	NHI-S_600_060	NHI-S_600_070

7.0

NHI-S 7.0



Length mm	4.5	5	6	7
∅ 7.0 mm	NHI-S_700_045	NHI-S_700_050	NHI-S_700_060	NHI-S_700_070

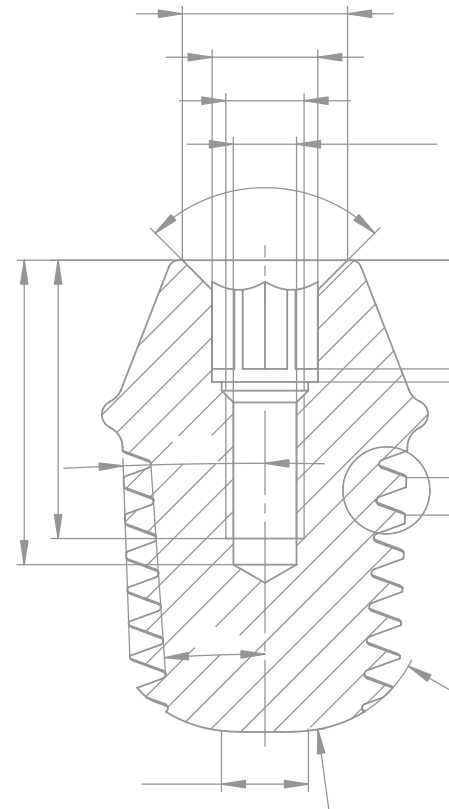
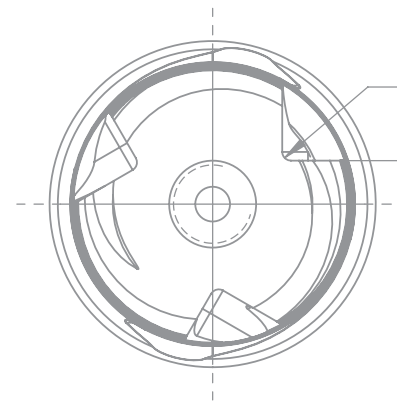

The set of NHI-S implants is designed for implantation and creation of comprehensive dental and orthopedic structures on the upper jaw in difficult clinical conditions of proximity (from 4,5 to 8,0 mm) of maxillary sinuses, as well as the real threat of sinuses perforation during implantation.

Such purposes and conditions of using the NHI-S implants have constituted the main technical requirements to the design and elaboration of their unique structural forms.

The main design features of the set of implants NHI-S shall include:

- more flat shape of the apical part;
- gradual increase of the basic cutting parameters along the cervical part, such as coils diameter and thread pitch, acuity, thickness and shape of threaded edges;
- availability of special, large-diameter pin (cylindrical

projection) in the implants' cervical part. Such pins, in conjunction with the apex flat form, prevent the implant's caving into the maxillary sinus.

The pin in conjunction with large diameter coils and wide flat-edge thread create a total area of biomechanical connection between the implants and the bone which guarantees a reliable osseointegration.

The technology of NHI-S implants inserting:

- assessment of the bone thickness and clinical condition thereof;
- careful selection of the most adequate implant;
- careful preparation of the bone bed, finally using the corresponding finishing drill-cutters from of the set NHB-10;
- implant's insertion into the prepared bone bed, ensuring tight joining of the pin to the bone surface.

GINGIVA-FORMERS SET



NHG 4.0

High mm	4 mm
1	NHG_400_100
2	NHG_400_200
3	NHG_400_300
4	NHG_400_400
5	NHG_400_500
6	NHG_400_600
7	NHG_400_700



NHG 5.0

High mm	5.0 mm
1	NHG_500_100
2	NHG_500_200
3	NHG_500_300
4	NHG_500_400
5	NHG_500_500
6	NHG_500_600
7	NHG_500_700



NHG 4.50

High mm	4.50 mm
1	NHG_450_100
2	NHG_450_200
3	NHG_450_300
4	NHG_450_400
5	NHG_450_500
6	NHG_450_600
7	NHG_450_700



NHG 5.50

High mm	5.50 mm
1	NHG_550_100
2	NHG_550_200
3	NHG_550_300
4	NHG_550_400
5	NHG_550_500
6	NHG_550_600
7	NHG_550_700

The set of gingiva-formers comprises a wide variety of elements, taking into consideration the most common and known features of the patients' gingival structure.

At present, this set comprises 28 elements, which are characterized by a variety of design shapes, diameters and heights.

Simplicity, efficiency and convenience in the process of inserting or replacing elements, provides the possibility to choose the most appropriate to the patients' gingiva characteristics element.

The elements of the set are made of titanium.

DIRECT ABUTMENTS

The direct abutment consists of a direct abutment and a plug screw M-1,8.

This set of abutments comprises six varieties, which are identical in design, but different in the gingival part diameter: 4.5, 5.0 and 5.5 mm. The plug screw is universal.

The main constituents of abutment are the following:

- connecting and fixing hexagon;
- hexagon platform;
- gingival part in six height sizes: 1, 2, 3, 4, 5 and 6 mm;
- abutment body in three height sizes: 5, 7 and 10 mm

Peculiarities of abutments, which constitute the superstructure:

- suitability for a comprehensive connection with any type of NANOPLANT HÖCHST system implant;

- hexagon extended size provide a tight connection between the abutments and the implants, and the firm fixation of the abutment in the implant's body;
- three stopper grooves in the abutment's upper part is designed for safer anti-rotational fixation thereof with the prosthetic part.

The main constituents of the plug screw:

- leading cylinder in the lower part which facilitates the screw insertion and positioning in the implant's thread;
- thread segment;
- conical neck-seal, which ensures a firm and tight

DIRECT ABUTMENTS 4.5



NSG 4.5

Length mm	GH: 1 mm
5	NSG_450_00_100_050
7	NSG_450_00_100_070
10	NSG_450_00_100_100



NSG 4.5

Length mm	GH: 4 mm
5	NSG_450_00_400_050
7	NSG_450_00_400_070
10	NSG_450_00_400_100



NSG 4.5

Length mm	GH: 2 mm
5	NSG_450_00_200_050
7	NSG_450_00_200_070
10	NSG_450_00_200_100



NSG 4.5

Length mm	GH: 5 mm
5	NSG_450_00_500_050
7	NSG_450_00_500_070
10	NSG_450_00_500_100



NSG 4.5

Length mm	GH: 3 mm
5	NSG_450_00_300_050
7	NSG_450_00_300_070
10	NSG_450_00_300_100



NSG 4.5

Length mm	GH: 6 mm
5	NSG_450_00_600_050
7	NSG_450_00_600_070
10	NSG_450_00_600_100

DIRECT ABUTMENTS 5.0

5.0

NSG 5.0



Length mm	GH: 1 mm
5	NSG_500_00_100_050
7	NSG_500_00_100_070
10	NSG_500_00_100_100



NSG 5.0

Length mm	GH: 4 mm
5	NSG_500_00_400_050
7	NSG_500_00_400_070
10	NSG_500_00_400_100



NSG 5.0

Length mm	GH: 2 mm
5	NSG_500_00_200_050
7	NSG_450_00_200_070
10	NSG_500_00_200_100



NSG 5.0

Length mm	GH: 5 mm
5	NSG_500_00_500_050
7	NSG_500_00_500_070
10	NSG_500_00_500_100



NSG 5.0

Length mm	GH: 3 mm
5	NSG_500_00_300_050
7	NSG_500_00_300_070
10	NSG_500_00_300_100



NSG 5.0

Length mm	GH: 6 mm
5	NSG_500_00_600_050
7	NSG_500_00_600_070
10	NSG_500_00_600_100

DIRECT ABUTMENTS 5.5

5.5

NSG 5.5



Length mm	GH: 1 mm
5	NSG_550_00_100_050
7	NSG_550_00_100_070
10	NSG_550_00_100_100



NSG 5.5

Length mm	GH: 4 mm
5	NSG_550_00_400_050
7	NSG_550_00_400_070
10	NSG_550_00_400_100



NSG 5.5

Length mm	GH: 2 mm
5	NSG_550_00_200_050
7	NSG_550_00_200_070
10	NSG_550_00_200_100



NSG 5.5

Length mm	GH: 5 mm
5	NSG_550_00_500_050
7	NSG_550_00_500_070
10	NSG_550_00_500_100



NSG 5.5

Length mm	GH: 3 mm
5	NSG_550_00_300_050
7	NSG_550_00_300_070
10	NSG_550_00_300_100



NSG 5.5

Length mm	GH: 6 mm
5	NSG_550_00_600_050
7	NSG_550_00_600_070
10	NSG_550_00_600_100

ANGULATED ABUTMENTS

Angulated abutments shall be used, if the application of direct superstructure is impossible, difficult or unreasonable. Such situations include the following cases:

- anatomic and topographic features of the jaws, preventing parallel implants' installation and requiring one of the angulated abutments' application;
- all cases of impossible insertion of direct abutments or in cases of uncertainty of the safe functioning of orthopedic constructions based on such structures;
- when the insertion of a certain angulated superstructure ensures, to the fullest extent, the required aesthetics in the frontal dentition areas etc.

The set of angulated abutments, designed to satisfy the requirements to various prosthetics peculiarities, comprises a wide choice of abutments.

Due to this factor, it is possible to create superstructures with the following characteristics:

- hexagon platform diameters: 4.5, 5.0 and 5.5 mm;
- abutment vertical plane inclination: 15° and 25°;
- abutment horizontal plane rotation: ±30°;
- abutment height from gingival part: 5, 7 and 10 mm;
- abutment gingival part height: 1, 2, 3, 4, 5 and 6 mm.

ANGULATED ABUTMENTS 4.5



NSA 4.5



Length mm	GH: 1 mm
5	NSA_450_15_100_050
7	NSA_450_15_100_070
10	NSA_450_15_100_100



NSA 4.5

Length mm	GH: 4 mm
5	NSA_450_15_400_050
7	NSA_450_15_400_070
10	NSA_450_15_400_100



NSA 4.5

Length mm	GH: 2 mm
5	NSA_450_15_200_050
7	NSA_450_15_200_070
10	NSA_450_15_200_100



NSA 4.5

Length mm	GH: 5 mm
5	NSA_450_15_500_050
7	NSA_450_15_500_070
10	NSA_450_15_500_100



NSA 4.5

Length mm	GH: 3 mm
5	NSA_450_15_300_050
7	NSA_450_15_300_070
10	NSA_450_15_300_100



NSA 4.5

Length mm	GH: 6 mm
5	NSA_450_15_600_050
7	NSA_450_15_600_070
10	NSA_450_15_600_100



25°

NSA 4.5



Length mm	GH: 1 mm
5	NSA_450_25_100_050
7	NSA_450_25_100_070
10	NSA_450_25_100_100

NSA 4.5



Length mm	GH: 4 mm
5	NSA_450_25_400_050
7	NSA_450_25_400_070
10	NSA_450_25_400_100



NSA 4.5



Length mm	GH: 2 mm
5	NSA_450_25_200_050
7	NSA_450_25_200_070
10	NSA_450_25_200_100

NSA 4.5



Length mm	GH: 5 mm
5	NSA_450_25_500_050
7	NSA_450_25_500_070
10	NSA_450_25_500_100



NSA 4.5



Length mm	GH: 3 mm
5	NSA_450_25_300_050
7	NSA_450_25_300_070
10	NSA_450_25_300_100

NSA 4.5



Length mm	GH: 6 mm
5	NSA_450_25_600_050
7	NSA_450_25_600_070
10	NSA_450_25_600_100

ANGULATED ABUTMENTS 5.0

5.0 15°



NSA 5.0	
Length mm	GH: 1 mm
5	NSA_500_15_100_050
7	NSA_500_15_100_070
10	NSA_500_15_100_100



NSA 5.0	
Length mm	GH: 4 mm
5	NSA_500_15_400_050
7	NSA_500_15_400_070
10	NSA_500_15_400_100



NSA 5.0	
Length mm	GH: 2 mm
5	NSA_500_15_200_050
7	NSA_500_15_200_070
10	NSA_500_15_200_100



NSA 5.0	
Length mm	GH: 5 mm
5	NSA_500_15_500_050
7	NSA_500_15_500_070
10	NSA_500_15_500_100



NSA 5.0	
Length mm	GH: 3 mm
5	NSA_500_15_300_050
7	NSA_500_15_300_070
10	NSA_500_15_300_100



NSA 5.0	
Length mm	GH: 6 mm
5	NSA_500_15_600_050
7	NSA_500_15_600_070
10	NSA_500_15_600_100

5.0 25°



NSA 5.0	
Length mm	GH: 1 mm
5	NSA_500_25_100_050
7	NSA_500_25_100_070
10	NSA_500_25_100_100



NSA 5.0	
Length mm	GH: 4 mm
5	NSA_500_25_400_050
7	NSA_500_25_400_070
10	NSA_500_25_400_100



NSA 5.0	
Length mm	GH: 2 mm
5	NSA_500_25_200_050
7	NSA_500_25_200_070
10	NSA_500_25_200_100



NSA 5.0	
Length mm	GH: 5 mm
5	NSA_500_25_500_050
7	NSA_500_25_500_070
10	NSA_500_25_500_100



NSA 5.0	
Length mm	GH: 3 mm
5	NSA_500_25_300_050
7	NSA_500_25_300_070
10	NSA_500_25_300_100



NSA 5.0	
Length mm	GH: 6 mm
5	NSA_500_25_600_050
7	NSA_500_25_600_070
10	NSA_500_25_600_100

ANGULATED ABUTMENTS 5.5

5.5 15°



NSA 5.5

Length mm	GH: 1 mm
5	NSA_550_15_100_050
7	NSA_550_15_100_070
10	NSA_550_15_100_100



NSA 5.5

Length mm	GH: 4 mm
5	NSA_550_15_400_050
7	NSA_550_15_400_070
10	NSA_550_15_400_100

NSA 5.5

Length mm	GH: 2 mm
5	NSA_550_15_200_050
7	NSA_550_15_200_070
10	NSA_550_15_200_100



NSA 5.5

Length mm	GH: 5 mm
5	NSA_550_15_500_050
7	NSA_550_15_500_070
10	NSA_550_15_500_100



NSA 5.5

Length mm	GH: 3 mm
5	NSA_550_15_300_050
7	NSA_550_15_300_070
10	NSA_550_15_300_100



NSA 5.5

Length mm	GH: 6 mm
5	NSA_550_15_600_050
7	NSA_550_15_600_070
10	NSA_550_15_600_100

5.5 25°



NSA 5.5

Length mm	GH: 1 mm
5	NSA_550_25_100_050
7	NSA_550_25_100_070
10	NSA_550_25_100_100



NSA 5.5

Length mm	GH: 4 mm
5	NSA_550_25_400_050
7	NSA_550_25_400_070
10	NSA_550_25_400_100

NSA 5.5

Length mm	GH: 2 mm
5	NSA_500_25_200_050
7	NSA_500_25_200_070
10	NSA_500_25_200_100



NSA 5.5

Length mm	GH: 5 mm
5	NSA_500_25_500_050
7	NSA_500_25_500_070
10	NSA_500_25_500_100



NSA 5.5

Length mm	GH: 3 mm
5	NSA_500_25_300_050
7	NSA_500_25_300_070
10	NSA_500_25_300_100



NSA 5.5

Length mm	GH: 6 mm
5	NSA_500_25_600_050
7	NSA_500_25_600_070
10	NSA_500_25_600_100

SPHERICAL ABUTMENT NSKA - 1



4

NSKA-1

Length mm	GH: 1 mm
5	NSKA_1_400_050
10	NSKA_1_400_100
20	NSKA_1_400_200
30	NSKA_1_400_300
40	NSKA_1_400_400
50	NSKA_1_400_500
60	NSKA_1_400_600



5

NSKA-1

Length mm	GH: 1 mm
5	NSKA_1_500_050
10	NSKA_1_500_100
20	NSKA_1_500_200
30	NSKA_1_500_300
40	NSKA_1_500_400
50	NSKA_1_500_500
60	NSKA_1_500_600



4.5

NSKA-1

Length mm	GH: 1 mm
5	NSKA_1_450_050
10	NSKA_1_450_100
20	NSKA_1_450_200
30	NSKA_1_450_300
40	NSKA_1_450_400
50	NSKA_1_450_500
60	NSKA_1_450_600

1. Connection and safe fixing of removable prostheses on the implants are provided by means of two abutments of this construction:

- Direct abutment with spherical head and neck. This abutment shall be inserted into the implant by means of internal hexagon at the butt of spherical head and a hexagon 1.25 mm wrench. This superstructure, hereinafter – patrix, constitutes the implant part of the detachable connection.
- Prosthetic abutment, hereinafter – matrix, represents a titanium case with a dense nylon cap pressed therein. NSKA-1 superstructures comprise different nylon caps of various densities. The titanium case is fixed firmly in the removable prosthesis.
- Safe functioning of the removable prosthetic construction based on NSKA-1 superstructure is provided by means of solid spherical interlock, of the nylon cap matrix with the patrix neck.

2. Main structural constituents of spherical abutments:

- 2.50 mm diameter spherical head with and a butt hexagon;
- Neck coupling with a nylon cap of prosthetic superstructure;
- Gingival part;
- Neck of direct superstructure within the implant;
- Thread segment;
- Leading cylinder.

3. Spherical abutments NSKA-1 differ in the size of the gingival parts:

- Three diameter sizes – 4 mm, 4.5 mm and 5.0 mm;
- Seven height sizes – 0.50 mm, 1.00 mm, 2.00 mm, 3.00 mm, 4.00 mm, 5.00 mm and 6.00 mm.

SPHERICAL ABUTMENT NSKA - 2



4

NSKA-2

Length mm	GH: 1 mm
5	NSKA_2_400_050
10	NSKA_2_400_100
20	NSKA_2_400_200
30	NSKA_2_400_300
40	NSKA_2_400_400
50	NSKA_2_400_500
60	NSKA_2_400_600



5

NSKA-2

Length mm	GH: 1 mm
5	NSKA_2_500_050
10	NSKA_2_500_100
20	NSKA_2_500_200
30	NSKA_2_500_300
40	NSKA_2_500_400
50	NSKA_2_500_500
60	NSKA_2_500_600



4.5

NSKA-2

Length mm	GH: 1 mm
5	NSKA_2_450_050
10	NSKA_2_450_100
20	NSKA_2_450_200
30	NSKA_2_450_300
40	NSKA_2_450_400
50	NSKA_2_450_500
60	NSKA_2_450_600

1. Spherical abutment NSKA - 2 is designed to build removable prostheses on the implants, ensuring the possibility of immediate loading of the prosthetic device after completion of the implantation procedure (on the same day).

2. Connection and safe fixing of removable labile prostheses on the implants are provided by means of two abutments of the NSKA-2 superstructure:

- Direct abutment with special spherical head and neck. This abutment, considered as patrx, constitutes the implant part of the detachable connection. The patrx shall be inserted into the implant by means of the specially assigned body square part under the neck.

- Prosthetic abutment – matrix, shall be considered as counterpart of the detachable connection. Structurally, such matrix represents a titanium case with a resilient rubber ring pressed therein. Superstructure NSKA-2 comprises rubber rings of various density and elasticity. The titanium case is firmly fixed in the removable prosthesis.

- Safe functioning of the removable prosthetic construction based on the NSKA-2 superstructures is provided by means

of solid spherical interlock, of the rubber ring matrix with the patrx neck.

3. Main structural constituents of spherical abutments are the following:

- 1.8 mm diameter spherical head;
- Neck coupling with a resilient rubber ring of prosthetic abutment – matrix;
- Gingival part;
- Neck-seal of the spherical abutment within the implant;
- Thread segment;
- Leading cylinder

4. Spherical abutments of the construction NSKA-2 differ in their gingival parts size:

- Three diameter sizes – 4 mm, 4.5 mm and 5.0 mm;
- Seven height sizes – 0.50 mm, 1.00 mm, 2.00 mm, 3.00 mm, 4.00 mm, 5.00 mm and 6.00 mm.

IMPRESSION TAKING TRANSFER



NAT-1+2_K

Ø mm	Ø 3,75	Ø 4,20	Ø 4,75	Ø 5,20	Ø 5,25
1+2_K	NAT_375_1+2_K	NAT_420_1+2_K	NAT_475_1+2_K	NAT_520_1+2_K	NAT_575_1+2_K



NAT-1+2_L

Ø mm	Ø 3,75	Ø 4,20	Ø 4,75	Ø 5,20	Ø 5,25
1+2_L	NAT_375_1+2_L	NAT_420_1+2_L	NAT_475_1+2_L	NAT_520_1+2_L	NAT_575_1+2_L



NAT-3_K

Ø mm	Ø 3,75	Ø 4,20	Ø 4,75	Ø 5,20	Ø 5,25
3_K	NAT_375_3_K	NAT_420_3_K	NAT_475_3_K	NAT_520_3_K	NAT_575_3_K



NAT-3_L

Ø mm	Ø 3,75	Ø 4,20	Ø 4,75	Ø 5,20	Ø 5,25
3_L	NAT_375_3_L	NAT_420_3_L	NAT_475_3_L	NAT_520_3_L	NAT_575_3_L

The NANOPLANT HÖCHST System provides 2 types of impression taking transfers:

- monolithic transfer NAT-1+2;
- split two-component transfer, comprising an implant gingival part NAT-1 and impression parts NAT-2 and NAT-2a.

Based on these transfers, impressions can be taken in two ways:

- traditional
- innovative

The traditional method of taking impressions is performed by means of individual trays with perforation and monolithic transfer.

For the innovative method of taking impressions, less laborious and more operative, split transfer and traditional closed tray is used.

IMPLANTS' LABORATORY ANALOGUES



NHIA_K

Ø mm	Ø 3,75	Ø 4,20	Ø 4,75	Ø 5,20	Ø 5,25
K	NHIA_375_K	NHIA_420_K	NHIA_475_K	NHIA_520_K	NHIA_575_K



NHIA_L

Ø mm	Ø 3,75	Ø 4,20	Ø 4,75	Ø 5,20	Ø 5,25
L	NHIA_375_L	NHIA_420_L	NHIA_475_L	NHIA_520_L	NHIA_575_L

The NANOPLANT HÖCHST System comprises 5 types of laboratory analogues imitating 5 different implants with the following diameters:

- Ø = 3,75 mm,
- Ø = 4,20 mm,
- Ø = 4,75 mm,
- Ø = 5,20 mm,
- Ø = 5,75 mm.

INSTRUMENTS



NSD-125 wrench with 1.25 mm hexagon
The wrench is designated for the contra angle handpieces
Three dimensions: S, M, L.

NSD-125

mm	L	M	K
	NSD_125_L	NSD_125_M	NSD_125_K



NSDM-125 wrench with 1.25 mm hexagon
The wrench is designated for the manual installation of
any implant of the NANOPLANT HÖSHST System.
Three dimensions: S, M, L.

NSDM-125

mm	L	M	K
	NSDM_125_L	NSDM_125_M	NSDM_125_K



NSKS-125 special wrench
The wrench is designated for the installing of the screw
cap and abutments with 1.25mm hexagon.
Three dimensions: S, M, L.

NSKS-125

mm	L	M	K
	NSKS_125_L	NSKS_125_M	NSKS_125_K



NSKS-240 universal wrench with 2.40 mm hexagon
The wrench is designated for the implants' tightening by
means of 4- or 6-sided ratchets.
Three dimensions: S, M, L.

NSKS-240

mm	L	M	K
	NSKS_240_L	NSKS_240_M	NSKS_240_K

NANOPLANT HÖCHST System comprises a large variety of instruments that can satisfy all known requirements of surgeons and orthopedists, making their work highly efficient.

Like all constituent parts of the NANOPLANT HÖCHST System, which are elaborated and manufactured by the innovative German company Nanoplant-Höchst GmbH, the instruments are characterized by:

- original constructive decisions;

- involving of the recent methods and means of computer simulation and construction;
- manufacturing of high-quality alloys.

The construction of the instruments is improving and their assortment within the NANOPLANT HÖCHST System is widening in line with the development of international dental implantology and practical needs thereof.